

Absolute encoders - bus interfaces

Through hollow shaft

Optical multiturn encoders 18 bit ST / 16 bit MT, EtherCAT

EAL580-T - EtherCAT - *OptoTurn*[®]



EAL580 with through hollow shaft

Features

- Absolute encoder multiturn
- Optical sensing method
- Max. resolution: singleturn 18 bit, multiturn 16 bit
- Through hollow shaft
- LED status indicator
- EtherCAT
- Maximum resistant against magnetic fields

Optional

- B-side clamping
- Button for Preset

Technical data - electrical ratings

Voltage supply	10...30 VDC
Reverse polarity protection	Yes
Consumption w/o load	≤100 mA (24 VDC)
Interface	EtherCAT
Function	Multiturn
Steps per revolution	≤262144 / 18 bit (adjustable)
Number of revolutions	≤65536 / 16 bit (adjustable)
Total resolution	≤31 bit
Absolute accuracy	±0.01 ° (ST 18 bit / MT 13 bit) ±0.025 ° (ST 13 bit / MT 16 bit)
Sensing method	Optical
Interference immunity	DIN EN 61000-6-2
Emitted interference	DIN EN 61000-6-4
Status indicator	4x LED integrated in housing
Approval	UL approval / E63076

Technical data - mechanical design

Size (flange)	ø58 mm
Shaft type	ø10...14 mm (through hollow shaft)
Protection DIN EN 60529	IP 54, IP 65, IP 67
Operating speed	≤6000 rpm (mechanical) ≤6000 rpm (electric)
Starting acceleration	≤1000 U/s ²
Starting torque	≤0.04 Nm (+25 °C, IP 54)
Rotor moment of inertia	20 gcm ²
Materials	Housing: zinc diecast Flange: aluminium
Operating temperature	-40...+85 °C (see general information)
Relative humidity	95 % non-condensing
Resistance	DIN EN 60068-2-6 Vibration ±0.75 mm - 10-58 Hz 10 g - 58-2000 Hz DIN EN 60068-2-27 Shock 100 g, 2 ms
Weight approx.	500 g
Connection	Flange connector 3 x M12

Absolute encoders - bus interfaces
Through hollow shaft
Optical multiturn encoders 18 bit ST / 16 bit MT, EtherCAT

EAL580-T - EtherCAT - OptoTurn®

Part number

EAL580-

T			.		W	EC	.		0.	A
---	--	--	---	--	---	----	---	--	----	---

						<u>Operating temperature</u>
						A -40...+85 °C
						<u>Resolution</u>
						1316 13 bit singleturn / 16 bit multiturn
						1813 18 bit singleturn / 13 bit multiturn
						<u>Voltage supply</u>
						EC 10...30 VDC, EtherCAT
						<u>Connection</u>
						W Flange connector 3 x M12, 4-pin, radial
						<u>Protection</u>
						4 IP 54
						5 IP 65
						7 IP 67 (only clamping ring at A-side)
						<u>Specification hollow shaft</u>
						A ø10 mm, clamping ring at A side
						C ø12 mm, clamping ring at A side
						G ø12 mm, clamping ring at B side
						E ø14 mm, clamping ring at A side
						H ø14 mm, clamping ring at B side
						<u>Flange</u>
						N Without stator coupling
						B Torque pin ø4 x 15 mm, radial
						<u>Shaft type</u>
						T Through hollow shaft

Optional: /6104 Button for Preset

Absolute encoders - bus interfaces

Through hollow shaft

Optical multiturn encoders 18 bit ST / 16 bit MT, EtherCAT

EAL580-T - EtherCAT - OptoTurn®

Accessories

Connectors and cables

11034355	Cable connector M12, 4-pin, on both sides, D-coded, 5 m cable (Z 185.E05)
11174046	Cable connector M12, 4-pin, straight, D-coded, without cable (Z 185.S01)
11174047	Cable connector M12, 4-pin, angled, D-coded, without cable (Z 185.S02)
11034356	Female connector M12, 5-pin, A-coded, 5 m cable (Z 185.P05)
11212237	Female connector M12, 5-pin, A-coded, 10 m cable (Z 185.P10)

Mounting accessories

10139345	Torque support by rubber buffer for encoders with 15 mm pin (Z 119.041)
10147837	Spring coupling for one-side attachment, length 35 mm (Z 119.050)
10165157	Spring coupling for encoders with ø58 mm housing, hole distance 73 mm (Z 119.072)
11034121	Spring coupling for encoders with ø58 mm housing, hole distance 68 mm (Z 119.073)
11034123	Spring coupling for one-side attachment, length 115 mm (Z 119.076)
11003562	Spring coupling for encoders with ø58 mm housing, hole distance 63 mm (Z 119.082)
11177167	Self-tapping grounding screw (Z 119.100)

EtherCAT features

Bus protocol	EtherCAT
Device profile	Encoder-Profil CANopen CiA 406 Vers. 4.0.2 from 18.08.2016
Operating modes	Free Run, Synchronous with SM3 Event, DC Mode (Distributed Clocks)
Cycle time	Min. 62.5 µs
Features	<ul style="list-style-type: none"> - Gear factor (round shaft) and endless loop mode - Time stamp (time of position data acquisition) - Plausibility check of the configurable parameters - Comprehensive diagnostic functions - Preset button for position - File Access over EtherCAT (FoE)
Process data	<ul style="list-style-type: none"> - Position value 32 bits input data with/without speed 32 bits - Extensive process data mapping
LED status indicator	2x Link/Activity, RUN, ERR

Terminal assignment

Voltage supply

Pin	Assigned	Significance
1	UB	Voltage supply
2	d.u.	Do not connect
3	GND	Ground
4	d.u.	Do not connect



1 x flange connector M12 (male), A-coded

EtherCAT (data line)

Pin	Assigned	Significance
1	TxD+	Transmission data+
2	RxD+	Receiving data+
3	TxD-	Transmission data-
4	RxD-	Receiving data-



2 x flange connector M12 (female), D-coded

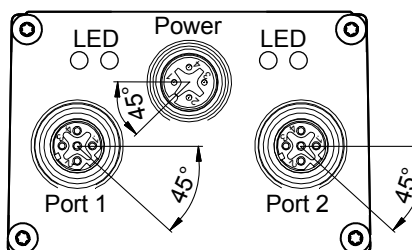

General information

Self-heating interrelated to speed, protection, attachment method and ambient conditions as well electronics and supply voltage must be considered for precise thermal dimensioning. Self-heating is supposed to approximates 7 K (IP 54 protection) respectively 8 K (IP 65 / IP 67 protection) per 1000 rpm. Operating the encoder close to the maximum limits requires measuring the real prevailing temperature at the encoder flange.

Absolute encoders - bus interfaces

Through hollow shaft

Optical multiturn encoders 18 bit ST / 16 bit MT, EtherCAT

EAL580-T - EtherCAT - *OptoTurn*[®]

Dimensions

Through hollow shaft, clamping ring at A side

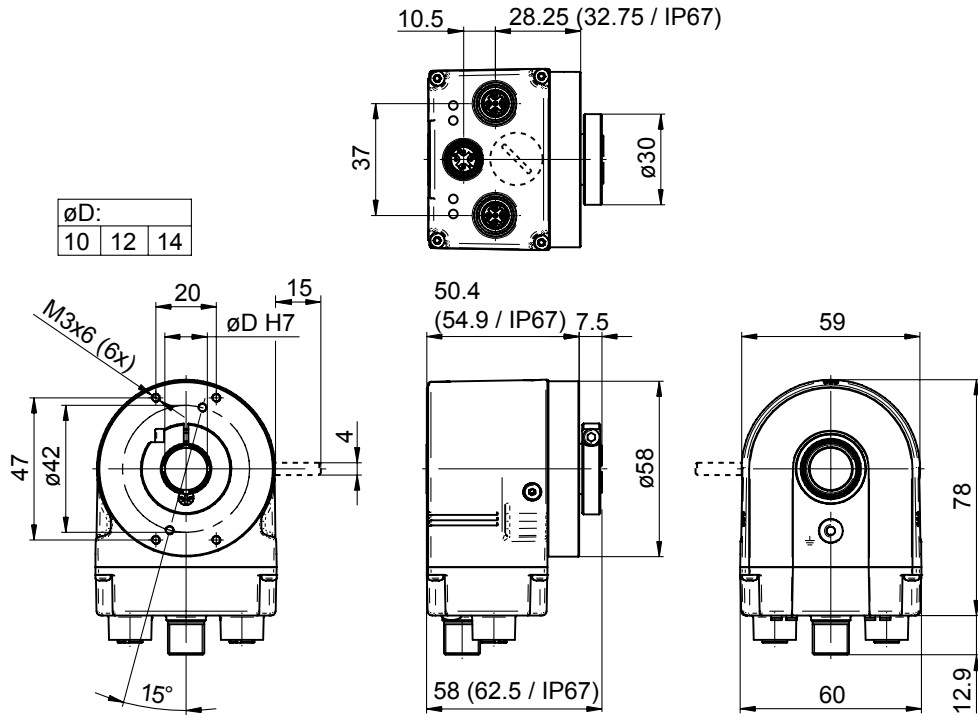

Through hollow shaft, clamping ring at B side

