



# HE6B Enabling Switch

## 3-position enabling switch with monitoring contacts IEC 60947-5-8 compliant (Note 1)

IDEC's 3-position enabling switches are installed in teach pendants of major robot manufacturers worldwide.



IEC 60947-5-8 compliant and smallest in its class (Note 2)

22 (L) × 47.7 (W) × 38.6 (H) mm

Lightweight

17 g  
Approx.

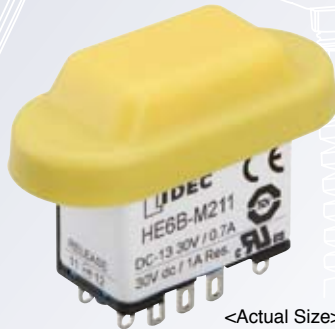

<Actual Size>

### IDEC's 3-position enabling switch compliant with IEC 60947-5-8

| Enabling Switch   | Grip Switch  | Teach Pendant  |
|---|--|--|
| <p>Five versions—including rectangular mounting hole and ø16mm round mounting hole—are available.</p>                     | <p>Light operating force model is available, providing comfortable and stress-free operation for many working hours.</p>                                     | <p>Ideal for installation in teach pendants for robots.</p>  |
| <ul style="list-style-type: none"> <li>• HE2B</li> <li>• HE3B</li> <li>• HE1B</li> <li>• HE5B</li> <li>• HE6B </li> </ul> | <ul style="list-style-type: none"> <li>• HE1G-L (light operating force type)</li> <li>• HE2G (compact/light operating force type)</li> <li>• HE1G</li> </ul> | <ul style="list-style-type: none"> <li>• HG1T</li> <li>• HG1H</li> <li>• HG2S</li> <li>• HG1U</li> </ul> |

Note 1: IEC 60947-5-8 Control circuit devices and switching elements – Three-position enabling switches  
Note 2: Based on IDEC research as of May 2010

# HE6B Enabling Switch

## 3-position enabling switch with monitoring contacts—Smallest in its class.

- Ergonomically-designed OFF-ON-OFF operation.
- The switch does not turn ON while returning from position 3 (OFF) to position 1 (OFF)  
IEC 60204-1 (2005), 10.9  
IEC 60947-5-8 (2006), 7.1.9
- Some teach pendants are equipped with two 3-position enabling switches, and when one switch is pressed to position 3 (OFF), the other switch must not enable machine operation even when pressed to position 2. Enabling of machine operation must resume after both switches are released. The monitoring switches monitor the OFF status of 3-position enabling switch, whether the button is returned to position 1 or the button is pressed to position 3 (monitor switches have direct opening action mechanism.)
- Two contacts are provided in a 3-position enabling switch so that even if one contact fails due to welding or short circuit, the other contact can disable machine operation.
- The waterproof rubber boot provides IP65 protection.



## Types

| Type             |   | Contact Configuration/No. of Contacts |                                  |                                   | Type No.   | Ordering Type No. | Package Quantity |
|------------------|---|---------------------------------------|----------------------------------|-----------------------------------|------------|-------------------|------------------|
|                  |   | 3-position Switch                     | Button Return Monitor Switch (↶) | Button Depress Monitor Switch (↷) |            |                   |                  |
| With Rubber Boot | Rubber Boot Material: Silicon Rubber<br>Color:<br>Y: yellow<br>B: black | 2                                     | 0                                | 0                                 | HE6B-M200* | HE6B-M200*        | 1                |
|                  |   | 2                                     | 1                                | 1                                 | HE6B-M211* | HE6B-M211*        | 1                |
|                  |   |                                       |                                  |                                   |            | HE6B-M200*PN10    | 10               |
|                  |   |                                       |                                  |                                   |            | HE6B-M211*PN10    | 10               |

- Specify rubber boot color code in place of \* in the Type No.

## Type No. Development

**HE6B - M 2 0 0 \***

**3-position Switch**  
2: 2 contacts

**Monitor Switch**  
00: No switch  
11: 1 contact of button return monitor switch  
1 contact of button depress monitor switch  
20: 2 contacts of button return monitor switch  
02: 2 contacts of button depress monitor switch  
(20 and 02 are not standard. Contact IDEC for details.)

**Rubber Boot Material, Color**  
Blank: No rubber boot  
Y: Silicon rubber, yellow (Note 1)  
B: Silicon rubber, black (Note 1)  
[N1]: NBR/PVC polyblend, gray (Not standard. Contact IDEC) (Note 2)

Note 1: Silicon rubber: Can be used in general factories. Remaining flexible in cold temperatures. Suitable for applications in a wide operating temperature range.  
Note 2: NBR/PVC polyblend: Oil-proof. Suitable for environments subjected to machine oil and for painting robots where silicon rubber cannot be used.

## Accessories

### • Replacement Rubber Boot

| Material, Color                         | Type No. | Ordering Type No. | Package Quantity |
|---|----------|-------------------|------------------|
| Silicon Rubber<br>Y: yellow<br>B: black | HE9Z-D6* | HE9Z-D6*PN10      | 10               |



- Specify rubber boot color code in place of \* in the Type No.

## Specifications

|   |   |
|---|---|
| Applicable Standards  | IEC 60947-5-1/EN60947-5-1<br>IEC 60947-5-8/EN60947-5-8 (TÜV approved)<br>GS-ET-22 (TÜV approved)<br>UL508 (UL recognized)<br>CSA C22.2 No.14 (c-UL recognized)  |
| Applicable Standards for Use                                    | ISO 12100/EN ISO 12100,<br>IEC 60204-1/EN 60204-1,<br>ISO 11161/EN ISO 11161,<br>ISO 10218-1/EN ISO 10218-1,<br>ANSI/RIA/ISO 10218-1,<br>ANSI/RIA/R15.06, ANSI B 11.19<br>ISO 13849-1/EN ISO 13849-1                                |
| Operating Temperature   | -25 to +60°C (no freezing)  |
| Relative Humidity   | 45 to 85% RH (no condensation)  |
| Storage Temperature   | -40 to +80°C (no freezing)  |
| Pollution Degree  | 2 (inside panel, terminal side)<br>3 (outside panel, operator side)   |
| Contact Resistance  | 50 mΩ maximum (initial value)   |
| Insulation Resistance   | Between live and dead metal parts:<br>100 MΩ minimum (500V DC megger)<br>Between terminals of different poles:<br>100 MΩ minimum (500V DC megger)   |
| Impulse Withstand Voltage                                       | 1.5 kV (3 position switch)<br>2.5 kV (monitor switch)   |
| Operating Frequency   | 1200 operations per hour  |
| Mechanical Durability   | Position 1→2→1: 1,000,000 operations minimum<br>Position 1→2→3→1: 100,000 operations minimum  |
| Electrical Durability   | 100,000 operations minimum (rated load)<br>1,000,000 operations minimum<br>(24V AC/DC, 100 mA)  |
| Shock Resistance  | Operating extremes: 150 m/s <sup>2</sup><br>Damage limits: 500 m/s <sup>2</sup>   |
| Vibration Resistance  | Operating extremes: 5 to 55 Hz, amplitude 0.5 mm<br>Damage limits: 16.7 Hz, amplitude 1.5 mm  |
| Terminal Style  | Solder terminal   |
| Applicable Wire   | 1 cable, 0.5 mm <sup>2</sup> maximum  |
| Solder Terminal Heat Resistance                                 | 310 to 350°C, 3 seconds maximum   |
| Terminal Tensile Strength                                       | 20N minimum   |
| Locking Ring Recommended Tightening Torque                      | 0.5 to 0.8 N·m  |
| Degree of Protection  | IP65 (IEC 60529)  |
| Conditional Short-circuit Current                               | 50A (125V): 3-position switch<br>(Use 120V/10A fast acting type fuse for short circuit protection.) (IEC 60127-1)<br>50A (250V): monitor switch<br>(Use 250V/10A fast acting type fuse for short circuit protection.) (IEC 60127-1) |
| Direct Opening Force  | 40N minimum (button release monitor and button depress monitor switches)  |
| Direct Opening Stroke (when pressing the entire button surface) | 0.9 mm minimum (button return monitor switch)<br>4.0 mm minimum (button depress monitor switch)   |
| Operator Strength   | 250N minimum<br>(when pressing the entire button surface)   |
| Weight (approx.)  | 17g   |

## Dimensions

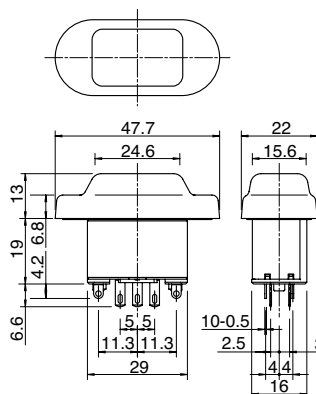

## Mounting Hole Layout

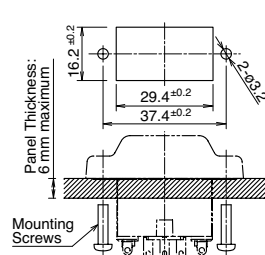

- Mounting screws: M3 screw × 2 (not attached and must be supplied by the user)
- Mounting screw length: 5 to 6 mm (panel thickness + gasket)

All dimensions in mm.

## Ratings

|                               |  |                               |                        |      |      |      |
|-------------------------------|--|-------------------------------|------------------------|------|------|------|
| Rated Insulation Voltage (Ui) |  | 125V (monitor switch: 250V)   |                        |      |      |      |
| Rated Thermal Current (Ith)   |  | 3A                            |                        |      |      |      |
| Rated Voltage (Ue)            |  | 30V                           | 125V                   | 250V |      |      |
| Rated Current (Ie)            | 3-position switch  | AC                            | Resistive Load (AC-12) | —    | 0.5A | —    |
|                               |  | DC                            | Inductive Load (AC-15) | —    | 0.3A | —    |
|                               | Button return monitor switch<br>Button depress monitor switch (NC) | AC                            | Resistive Load (DC-12) | 1A   | —    | —    |
|                               |  |                               | Inductive Load (DC-13) | 0.7A | —    | —    |
|                               |  | DC                            | Resistive Load (AC-12) | —    | 2A   | 1A   |
|                               |  |                               | Inductive Load (AC-15) | —    | 1A   | 0.5A |
| Contact Configuration         | 3-position switch  | 2 contacts                    |                        |      |      |      |
|                               | Button return monitor switch                                       | 0 to 1 contact                |                        |      |      |      |
|                               |  | Button depress monitor switch | 0 to 1 contact         |      |      |      |

- Minimum applicable load (reference value): 3V AC/DC, 5 mA (Applicable operation area depends on the operating conditions and load.)

### TÜV ratings:

3 position switch:  
AC-12 125V/0.5A  
DC-12 30V/1A  
DC-13 30V/0.7A

Monitor Switch:  
AC-15 250V/0.5A  
DC-13 125V/0.22A  
DC-13 30V/1A

### UL ratings:

3-position switch:  
125V AC/0.5A (Resistive)  
30V DC/1A (Resistive)  
Monitor switch:  
250V AC/0.5A (General use)  
30V DC/1A (General use)

## Operating Characteristics

### • HE6B-M211

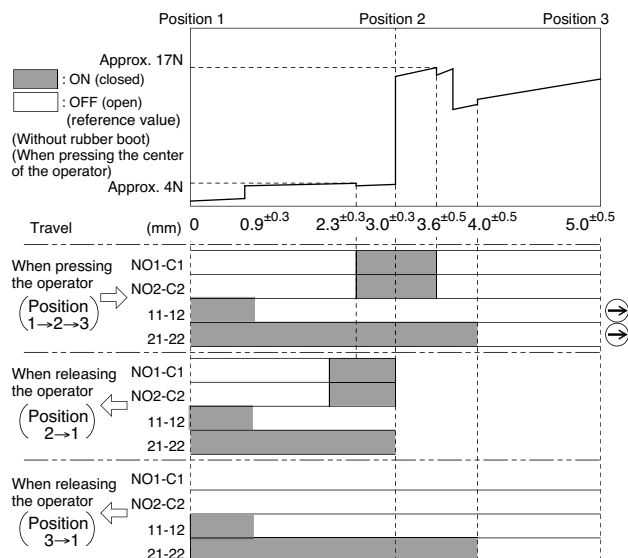

### Notes:

- When a rubber boot is used, the operating force depends on the operating temperature.
- The operating force to move the button from position 2 to position 3 can be changed. For details, contact IDEC.

## Terminal Arrangement (bottom view)

### • HE6B-M211

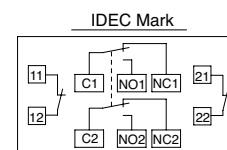

- 3-position switch (Note): 2 contacts
- Button return monitor switching: 1 contact, terminal nos. 11-12
- Button depress monitor switch: 1 contact, terminal nos. 21-22
- There are no terminal nos. 11-22 and 21-22 for HE6B-M200.

Note: Use NO and C terminals for OFF→ON→OFF 3-position switch (NC terminal is not used.)

## Safety Precautions

- The HE6B enabling switch has been designed for industrial purposes. Use of the HE6B enabling switch for residential, commercial, or lighting purposes may cause unwanted electromagnetic disturbances in which case the user may be required to take adequate mitigation measures.
- In order to avoid electric shock or fire, turn the power off before installation, removal, wiring, maintenance, or inspection of the enabling switch.
- Provide sufficient strength to the mounting panel. Insufficient strength of the mounting panel or excessive operating force may damage the enabling switch, resulting in electric shock or fire.
- Use wires of the proper size to meet voltage and current requirements, and solder the wires correctly according to the wiring instruction described below. If soldering is incomplete, the wire may heat during operation, causing a fire hazard.
- When using the enabling switch in a safety related part of a control system, use the enabling switch properly in accordance with the safety standards and regulations of the actual machine, system, and application, of the country or region where the enabling switch is used. Also, perform a risk assessment before using the enabling switch.
- Do not disable the safety function of the enabling switch by using tape, elastic band, or by disfiguring the rubber boot, otherwise the loss of enabling switch function may cause serious accidents.

## Instructions

### Operating Instructions

- 3-position enabling switches on teach pendants are used to enable machine operation in a hazardous area only when pressed to position 2 (pressed for 3 mm). Systems must be designed to enable machine operation when the enabling switch is in position 2 only.
- In order to ensure a high safety level of the system, connect the two contacts of the 3 position enabling switch to a disagreement detection circuit (e.g. safety relay module). (ISO 13849-1/EN954-1)
- Because the two contacts are designed to operate independently, pressing the edge of a button turns on one contact earlier than the other contact, causing a delay in operation. To avoid this, always press the center of the button.
- Perform a risk assessment in actual applications as strong force may be applied to a 3-position enabling switch when depressed to position 3.
- Perform a risk assessment for the shape and structure of the part, where the enabling switch is installed, to prevent unintended operation of the enabling switch. For example, an enabling switch protruding from the teach pendant may result in an unintended operation of the enabling switch.
- Because strong force may be applied to a 3-position enabling switch when depressed to position 3, provide sufficient strength to the part where the 3-position enabling switch will be mounted.

### Installation

- The ridge on the bottom of rubber boot serves as a seal, and waterproof characteristics are attained when the ridge is tightly installed in a mounting panel. When the mounting panel is bent and the ridge cannot be pressed flush to the panel, add a reinforcing rib to secure the boot to the mounting panel.
- If the mounting panel is deformed, waterproof characteristics of the enabling switch with rubber boot cannot be achieved. Make sure that the mounting panel has sufficient strength.

- The edge of rubber boot may stick out if excessive force is applied. When such an event is anticipated, it is recommended to embed the rubber boot in the mounting panel as shown in the figure below.

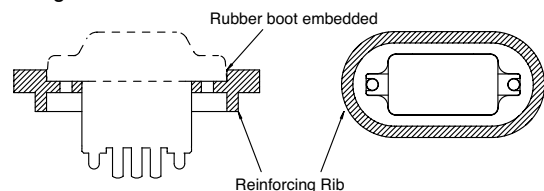

- When an enabling switch with a rubber boot is mounted in a hermetically-sealed control box, a large change in internal air pressure may cause the rubber boot to inflate and deflate, affecting the performance of the enabling switch. Check periodically to make sure that the enabling switch operates correctly.

### Wiring Instructions

- Applicable wire size: 0.5 mm<sup>2</sup> maximum × 1 pc.
- Solder the terminal at a temperature of 310 to 350°C maximum within 3 seconds using a soldering iron. Do not use flow or dip soldering. Sn-Ag-Cu type is recommended when using lead-free solder.
- When soldering, take care not to touch the enabling switch with the soldering iron. Also ensure that no tensile force is applied to the terminals. Do not bend or apply excessive force to the terminals.
- Use non-corrosive liquid rosin as soldering flux.

Specifications and other descriptions in this catalog are subject to change without notice.



## IDEC CORPORATION

7-31, Nishi-Miyahara 1-Chome, Yodogawa-ku, Osaka 532-8550, Japan  
Tel: +81-6-6398-2571, Fax: +81-6-6392-9731  
E-mail: marketing@idec.co.jp

**IDEC CORPORATION (USA)**  
1175 Elko Drive, Sunnyvale, CA 94089-2209, USA  
Tel: +1-408-747-0550 / (800) 262-IDEC (4332)  
Fax: +1-408-744-9055 / (800) 635-6246  
E-mail: opencontact@idec.com

**IDEC CANADA LIMITED**  
3155 Pepper Mill Court, Unit 4, Mississauga,  
Ontario, L5L 4X7, Canada  
Tel: +1-905-890-8561, Toll Free: (888) 317-4332  
Fax: +1-905-890-8562  
E-mail: sales@ca.idec.com

**IDEC AUSTRALIA PTY. LTD.**  
2/3 Macro Court, Rowville, Victoria 3178, Australia  
Tel: +61-3-9763-3244, Toll Free: 1800-68-4332  
Fax: +61-3-9763-3255  
E-mail: sales@au.idec.com

**IDEC ELECTRONICS LIMITED**  
Unit 2, Beechwood, Chineham Business Park,  
Basingstoke, Hampshire RG24 8WA, UK  
Tel: +44-1256-321000, Fax: +44-1256-327755  
E-mail: sales@uk.idec.com

**IDEC ELEKTROTECHNIK GmbH**  
Wendenstrasse 331, 20537 Hamburg, Germany  
Tel: +49-40-25 30 54 - 0, Fax: +49-40-25 30 54 - 24  
E-mail: service@idec.de

**IDEC (SHANGHAI) CORPORATION**  
Room 608-609, 6F, Gangtai Plaza, No. 700,  
Yan'an East Road, Shanghai 200001, PRC  
Tel: +86-21-5353-1000, Fax: +86-21-5353-1263  
E-mail: idec@cn.idec.com

**IDEC (BEIJING) CORPORATION**  
Room 211B, Tower B, The Grand Pacific Building,  
8A Guanghua Road, Chaoyang District,  
Beijing 100026, PRC  
Tel: +86-10-6581-6131, Fax: +86-10-6581-5119

**IDEC (SHENZHEN) CORPORATION**  
Unit AB-3B2, Tian Xiang Building, Tian'an Cyber Park,  
Fu Tian District, Shenzhen, Guang Dong 518040, PRC  
Tel: +86-755-8356-2977, Fax: +86-755-8356-2944

**IDEC IZUMI (H.K.) CO., LTD.**  
Units 11-15, Level 27, Tower 1,  
Millennium City 1, 388 Kwun Tong Road,  
Kwun Tong, Kowloon, Hong Kong  
Tel: +852-2803-8989, Fax: +852-2565-0171  
E-mail: info@hk.idec.com

**IDEC TAIWAN CORPORATION**  
8F-1, No. 79, Hsin Tai Wu Road, Sec. 1,  
Hsi-Chih, Taipei County, Taiwan  
Tel: +886-2-2698-3929, Fax: +886-2-2698-3931  
E-mail: service@tw.idec.com

**IDEC IZUMI ASIA PTE. LTD.**  
No. 31, Tannery Lane #05-01,  
HB Centre 2, Singapore 347788  
Tel: +65-6746-1155, Fax: +65-6844-5995  
E-mail: info@sg.idec.com