

Mini Horns Sirens Buzzer / Electronic Buzzers 118 483/119 483

Electr. Buzzer WM Contin. tone 24VAC/DC

Part No.: 118.483.15

**MECHANICAL DATA**

Height	80 mm
Diameter	70 mm
Materials	PC/ABS
Housing colour	Grey
Protection category	IP33
Connection	Flat plug
Type of fixing	Wall mounting
Working temperature minimum	0°C
Working temperature maximum	+60°C
Weight with packaging	114 g
Product weight	88 g

ELECTRICAL DATA

Operating voltage	24V
Operating voltage type	AC/DC
Operating voltage frequency	50Hz
Operating voltage tolerance	+/- 10%
Rated operational voltage	24 VDC
Rated operational current	20 mA
Rated inrush current	<500mA
Protection class	Protection class 2
Pollution degree	2

ACUSTICAL DATA

Volume (max) at 1m distance	90,0 dB (A)
Acoustic signal image	Continuous tone
Audio frequency	2400 Hz
Acoustic service life	5,000 h minimum

APPROVAL DATA

Conforms with CE	Yes
WEEE	Yes
Conforms with ATEX-directive	No
Conforms with CCC	No
Conforms with UL	No
Conforms with FCC	No
Conforms with IC	No
EAC certificate available	Yes
Conforms with UKCA (Importer)	Yes (WERMA (UK) Ltd.)



For additional installation and mounting information, refer to the appropriate user guide at www.werma.com. This printed copy is for information only and is subject to alteration.

Mini Horns Sirens Buzzer / Electronic Buzzers 118 483/119 483

Electr. Buzzer WM Contin. tone 24VAC/DC

Conforms with AS-I	No
ICAO Certification	No
Conforms with DNV	No
Conforms with RoHS CN	No
Conforms with VdS	No

DRAWING

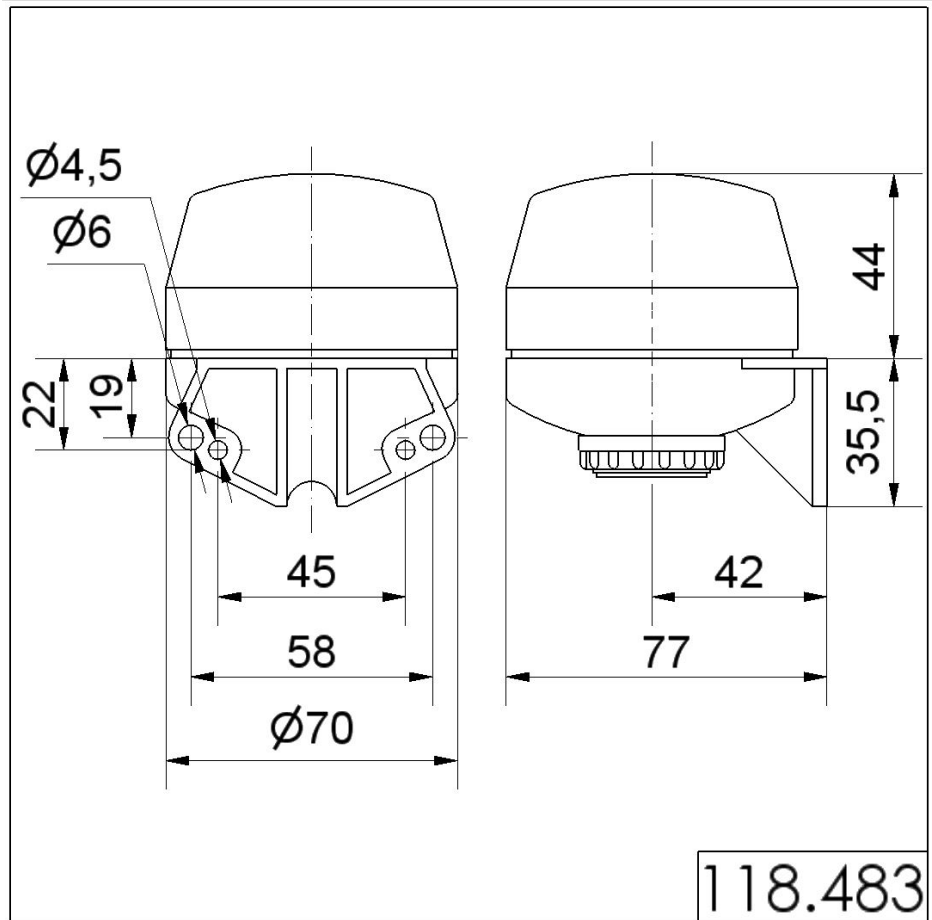

For additional installation and mounting information, refer to the appropriate user guide at www.werma.com. This printed copy is for information only and is subject to alteration.