

TAD091

TAD050KLER12-A-ZKG/US

Temperature sensors

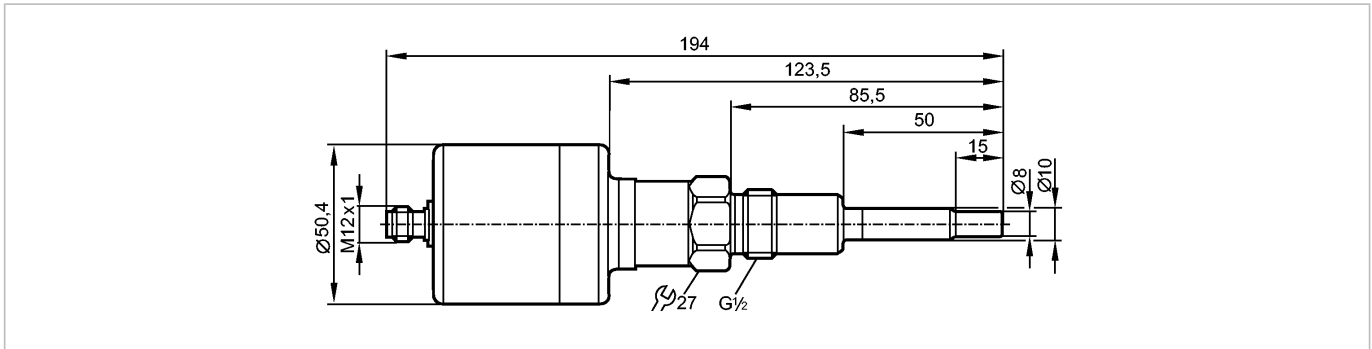

IO-Link

Including free 5-point calibration certificate.

Product characteristics

Temperature transmitter with diagnostic output
Process connection: G 1/2 A
Installation length EL: 50 mm
Redundant sensor elements with backup function
Analog output 4...20 mA (NAMUR NE43, NE89)
Diagnostic output for drift and fault monitoring
Measuring range: -25...160 °C / -13...320 °F
Measuring element: 1 x Pt 1000 + 1 x NTC, thermally coupled, with backup function (temperature measuring even if one of the two sensor elements fails)
Factory setting: 0...150 °C / 32...302 °F

Application

Application	liquids and gases
Pressure rating [bar]	50
Minimum installation depth [mm]	25

Electrical data

Electrical design	DC PNP/NPN
Operating voltage [V]	18...32
Current consumption [mA]	6 (24 V)
Protection class	III
Reverse polarity protection	yes

Outputs

Output	Analog output 4...20 mA (NAMUR NE43, NE89) Diagnostic output for drift and fault monitoring
Output function	normally open / normally closed / heartbeat programmable, 4...20 mA analog
Current rating [mA]	250
Voltage drop [V]	< 2
Short-circuit protection	yes (non-latching)
Overload protection	yes
Analog output	4...20 mA; Rmax [Ω]: (Ub - 15 V) x 50

Measuring / setting range



TAD091

TAD050KLER12-A-ZKG/US

Temperature sensors

Measuring range, (scalable)	-25...160 °C	-13...320 °F
Factory setting	0...150 °C / 32...302 °F	
Drift warning °C / °F	0.20...5.00 / 0.4...9.0	
Drift alarm °C / °F	0.20...5.00 / 0.4...9.0	
Setting range in steps of	0.05 °C	0.1 °F
Resolution		
Analog output [K]	0.05	

Accuracy / deviations

Analog output [K]	± 0.2 (-10...100°C); ± 0.3 (-25...-10/100...150°C); ± 0.5 (150...160°C) *)	
Temperature coefficients (in % of the span per 10 K)	< ± 0.01 **)	
Drift monitoring [K]	± 0.2 (-10...100°C); ± 0.3 (-25...-10/100...150°C); ± 0.5 (150...160°C) *)	

Reaction times

Power-on delay time [s]	8	
Dynamic response T05 / T09 [s]	3 / 6	
Integrated watchdog	yes	

Software / programming

Programming options	Drift warning / drift alarm threshold; Fail-Safe; display unit; scaling of the analog output; redundancy switching; behaviour of the diagnostic output; output polarity; normally open / normally closed	
---------------------	--	--

Interfaces

IO-Link Device		
Transfer type	COM1 (4.8 kBaud)	
IO-Link revision	1.1	
SDCI standard	IEC 61131-9 CDV	
IO-Link Device ID	323 d / 00 01 43 h	
Profiles	Smart Sensor	
Function class	Device Identification	
Function class	Device Diagnosis	
SIO mode	yes	
Required master port class	A	
Process data analogue	1	
Process data binary	1	
Min. process cycle time [ms]	18.8	

Environment

Ambient temperature [°C]	-25...70	
Storage temperature [°C]	-40...85	
Protection	IP 68 / IP 69K	

Tests / approvals

EMC	EN 61000-6-2 EN 61000-6-3	
Shock resistance	DIN EN 68000-2-27:	50 g (11 ms)
Vibration resistance	DIN EN 60068-2-6	20 g (10...2000 Hz)
MTTF [Years]	213	

Mechanical data

TAD091

TAD050KLER12-A-ZKG/US

Temperature sensors

Process connection	G ½ A	
Materials (wetted parts)	stainless steel 316L / 1.4404; surface characteristics Ra: < 0.6	
Probe length L [mm]	50	
Installation length EL [mm]	50	
Housing materials	stainless steel 316L / 1.4404; PEI; FPM	
Tightening torque [Nm]	30...50	
Weight [kg]	0.36	

Electrical connection

Connection	M12 connector; gold-plated contacts
------------	-------------------------------------

Wiring

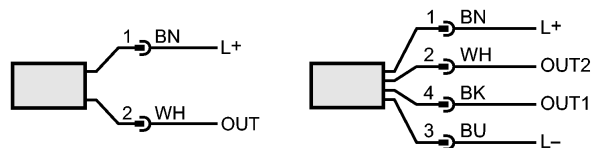

connection for 2-wire operation
 OUT: Analog output

connection for 3-wire operation
 OUT2: Analog output
 OUT1: Diagnosis / IO-Link

Remarks

Remarks	cULus - Class 2 source required *) probe completely inserted into the measured medium up to the sealing chamfer **) In case of deviation from the reference condition 25 ± 5 °C
---------	---

Pack quantity [piece]	1
-----------------------	---

Other data

Function class	Process Data Variables
----------------	------------------------